

Sprinter 311 CDI Medium HR Van

| | |
|------------------------------|--|
| ENGINE POWER (hp) | 109 |
| GVW (kg) | 3500 |
| WHEELBASE (mm) | 3665 |
| LOAD SPACE (m ³) | 10.5 |
| LOAD LENGTH (mm) | 3265 |
| WARRANTY | 3 years/ unlimited miles |
| CORROSION WARRANTY | 12 years |
| SERVICING | ASSYST - variable 24000-30000 Miles |
| ROADSIDE ASSISTANCE | 3 years |

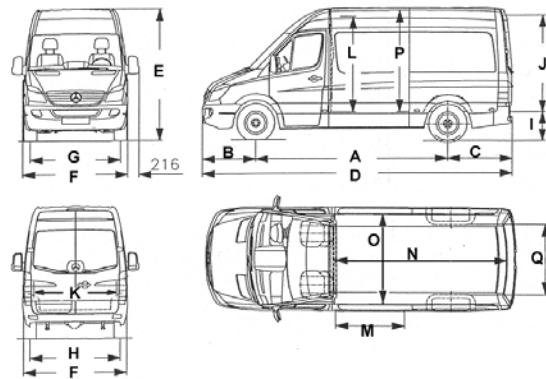

EXTERIOR DIMENSIONS (MM)

| | |
|--------------------------------------|------|
| A Wheelbase | 3665 |
| B Front overhang | 1004 |
| C Rear Overhang | 1240 |
| D Overall Length | 5910 |
| E Overall Height | 2700 |
| F Overall Width | 1993 |
| G Front Track | 1710 |
| H Rear Track | 1716 |
| Turning circle (wall to wall) (m) | 13.6 |

LOAD ACCESS DIMENSIONS (MM)

| | |
|-----------------------|------|
| I Rear Loading Height | 666 |
| J Rear Door Height | 1840 |
| K Rear Door Width | 1562 |
| L Side Door Height | 1816 |
| M Side Door Width | 1300 |

LOAD SPACE DIMENSIONS (MM)

| | |
|-----------------------------|------|
| N Load Length | 3265 |
| O Load Width | 1736 |
| P Interior Height | 1940 |
| Q Width between wheelarches | 1350 |
| Load Cube (m ³) | 10.5 |

ENGINE

| | |
|---------------------|---|
| Type | Mercedes-Benz 4-cylinder Diesel Turbocharged & Intercooled with Common Rail direct injection system |
| Capacity | 2.15 litres |
| Maximum power | 109 hp @ 3800 rpm 80kW @ 3800 rpm |
| Maximum Torque | 280 Nm @ 1600-2500 rpm |
| Emission compliance | Euro 4 |

ELECTRICAL

| | |
|-------------|--|
| Battery | 12 volts, 74 Amp/ hour |
| Alternator | 90 Amp |
| Road Lights | Halogen headlamps with headlamp levelling; indicators; indicator side repeaters in exterior mirrors; tail lights (reverse, fog lights integrated in cluster) |

AXLE RATIOS & VEHICLE PERFORMANCE

| | |
|--------------------------|-------|
| Standard Axle Ratio | 4.182 |
| Geared Speed (mph) | 92 |
| Maximum Gradeability (%) | 40+ |

WEIGHTS (KG)

| | |
|-----------------|------|
| Plated Weights: | |
| Front Axle | 1650 |
| Rear Axle | 2250 |
| GVW | 3500 |
| GTW (braked) | 5500 |
| Kerb Weights: * | |
| Front Axle | 1258 |
| Rear Axle | 904 |
| Total | 2162 |
| Payload | 1338 |

* According to DIN 70020: incl. driver (68kg), luggage (7kg) and tank 90% full

TRANSMISSION

| | |
|-----------------------|----------------------------------|
| Gearbox | Mercedes-Benz 6 sp. manual |
| Gear Ratios - 1st/Top | 5.014/ 0.797 |
| Gear Lever Position | Dash |
| Clutch | Single dry plate, 240mm diameter |

BRAKE SYSTEM

| | |
|---------------|--|
| Type | Dual circuit hydraulic brake with vacuum servo boost |
| Front/ Rear | Ventilated Disc/ Disc |
| Parking Brake | Floor mounted handbrake lever acting on rear axle |
| Enhancements | The system incorporates: Adaptive ESP, ABS, ASR (traction control), BAS (Brake Assist) and EBD (Electronic Brake force Distribution). Electronic Stability Programme is adaptive according to payload. |

FUEL TANK

| | |
|------|---|
| Size | 75 litres; plastic; filler on nearside 'B' pillar (secured behind hinged panel) |
|------|---|

STEERING

Type Rack & pinion; speed sensitive; power assisted

WHEELS & TYRES

Drive Rear wheels
Tyres 235/65R16
Wheels 6.5J x 16
Spare wheel Under rear of vehicle

SUSPENSION

Front MacPherson strut independent with transverse leaf spring
Rear Parabolic leaf springs
Shock absorbers Front and rear
Anti-roll bars Front and rear

CAB

Access to cab: Wide opening driver and passenger doors. Plastic coated entry steps.

Security: Remote central locking, Thatcham Cat 2 engine immobiliser, Attack resistant steering lock, door locks and handles, locking glove box, full height steel bulkhead, interlocked radio CD.

Airbags: Driver's airbag standard with belt tensioner and belt-force limiter. Front passenger airbag, thorax airbags and window bags can also be specified as options.

Seating & Trim 3-way adjustable driver's seat with head restraint; dual passenger seat; three point inertia reel seat belts to all seats. Hard wearing cloth seats; door mounted arm rests; passenger grab handle; moulded ergonomic facia; padded steering wheel with impact resistance centre; cab headlining.

Refinements: Comprehensive insulation from road and engine noise; ashtray; cab interior lighting including map reading light; cigarette lighter; stereo radio/CD with two speakers.

Controls: Hazard warning lights; heater and demister with multiple outlets; horn on steering wheel boss; key start with steering lock and transponder, engine immobiliser; left hand stalk for indicators, lights, main beam, headlamp flasher and parking lights; right hand stalk for two-speed wipers, intermittent wipe and wash/wipe; recirculating air switch and four-speed fan with direction air flow switch.

Instruments: ASSYST - flexible servicing system; coolant temperature gauge; digital clock; digital odometer; fuel gauge; rev counter; speedometer.

CAB (CONT'D)

Warning Lights: ESP/ABS/ASR/EBD warning lights; battery charging indicator; brake pad wear; direction indicators; hazard lights; low brake fluid level; low engine oil; low windscreen washer fluid level; main beam/flasher; parking brake; rear fog lamp.

Visibility: Electrically operated deep opening side windows and fixed quarterlights; laminated windscreen; two large exterior rear view mirrors with separate wide angle lenses; two sunvisors plus shaded windscreen centre.

Stowage: Large pockets in both doors with holders for large bottles; A4 oddments tray on centre of dash; shelves to left and right on instrument panel; 4 cup holders; shelf above windscreen; locking glove compartment; compartment under fold-up passenger seat. Pull-out tray in back of dual passenger seat.

CONSTRUCTION AND FINISH

Construction: All steel integral body/cab.

Body protection: Phosphate treatment, primer and gloss paint finish; floor panels at all joins and contact points on body areas susceptible to corrosion are galvanised; underbody and wheel arches are undersealed with PVC and rust inhibitor.

Service Access: Internally released hinged bonnet for access to - air filter with condition indicator; clutch/brake fluid; engine coolant; engine oil dipstick/filler cap; power steering reservoir; water trap for diesel system; windscreen washer reservoir.

Bumpers: Moulded in damage-resistant, impact-absorbing plastic.

CARGO AREA

Side Access: Nearside lockable sliding side load door with internal access step.

Rear Access: Lockable rear doors with 2 stops. Grab handle on right-hand door pillar. Rear door opening angle of 270°

Interior: Interior load area lighting switched from dashboard or activated by nearside or rear loading doors; wooden floor with bonded resin non-slip finish; flat-topped wheel arches.

Load Restraint: Steel bulkhead; load lashing rings recessed in floor.

Terms & Conditions

Please refer to the latest editions of the Mercedes-Benz Recommended List Price documents for availability and prices of models and optional equipment. The right is reserved to alter specification or equipment without notice. All specifications refer to vehicles sourced in the UK from DaimlerChrysler UK Ltd or their appointed Mercedes-Benz Retail Partners. All weights and dimensions quoted are approximate and subject to normal manufacturing tolerances of +/- 5%.

Sprinter 311 CDI Long HR Van

| | |
|------------------------------|--|
| ENGINE POWER (hp) | 109 |
| GVW (kg) | 3500 |
| WHEELBASE (mm) | 4325 |
| LOAD SPACE (m ³) | 14.0 |
| LOAD LENGTH (mm) | 4300 |
| WARRANTY | 3 years/ unlimited miles |
| CORROSION WARRANTY | 12 years |
| SERVICING | ASSYST - variable 24000-30000 Miles |
| ROADSIDE ASSISTANCE | 3 years |

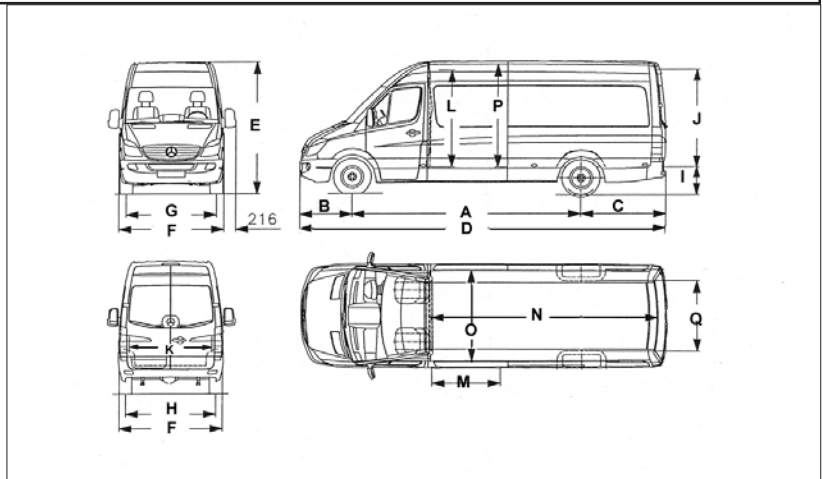

EXTERIOR DIMENSIONS (MM)

| | |
|--------------------------------------|------|
| A Wheelbase | 4325 |
| B Front overhang | 1004 |
| C Rear Overhang | 1615 |
| D Overall Length | 6945 |
| E Overall Height | 2700 |
| F Overall Width | 1993 |
| G Front Track | 1710 |
| H Rear Track | 1716 |
| Turning circle (wall to wall) (m) | 15.6 |

LOAD ACCESS DIMENSIONS (MM)

| | |
|-----------------------|------|
| I Rear Loading Height | 660 |
| J Rear Door Height | 1840 |
| K Rear Door Width | 1562 |
| L Side Door Height | 1816 |
| M Side Door Width | 1300 |

LOAD SPACE DIMENSIONS (MM)

| | |
|-----------------------------|------|
| N Load Length | 4300 |
| O Load Width | 1736 |
| P Interior Height | 1940 |
| Q Width between wheelarches | 1350 |
| Load Cube (m ³) | 14.0 |

ENGINE

| | |
|---------------------|---|
| Type | Mercedes-Benz 4-cylinder Diesel Turbocharged & Intercooled with Common Rail direct injection system |
| Capacity | 2.15 litres |
| Maximum power | 109 hp @ 3800 rpm 80kW @ 3800 rpm |
| Maximum Torque | 280 Nm @ 1600-2500 rpm |
| Emission compliance | Euro 4 |

ELECTRICAL

| | |
|-------------|--|
| Battery | 12 volts, 74 Amp/ hour |
| Alternator | 90 Amp |
| Road Lights | Halogen headlamps with headlamp levelling; indicators; indicator side repeaters in exterior mirrors; tail lights (reverse, fog lights integrated in cluster) |

AXLE RATIOS & VEHICLE PERFORMANCE

| | |
|--------------------------|-------|
| Standard Axle Ratio | 4.182 |
| Geared Speed (mph) | 92 |
| Maximum Gradeability (%) | 40+ |

WEIGHTS (KG)

| | |
|-----------------|------|
| Plated Weights: | |
| Front Axle | 1650 |
| Rear Axle | 2250 |
| GVW | 3500 |
| GTW (braked) | 5500 |
| Kerb Weights: * | |
| Front Axle | 1302 |
| Rear Axle | 1011 |
| Total | 2313 |
| Payload | 1187 |

* According to DIN 70020: incl. driver (68kg), luggage (7kg) and tank 90% full

TRANSMISSION

| | |
|-----------------------|----------------------------------|
| Gearbox | Mercedes-Benz 6 sp. manual |
| Gear Ratios - 1st/Top | 5.014/ 0.797 |
| Gear Lever Position | Dash |
| Clutch | Single dry plate, 240mm diameter |

BRAKE SYSTEM

| | |
|---------------|--|
| Type | Dual circuit hydraulic brake with vacuum servo boost |
| Front/ Rear | Ventilated Disc/ Disc |
| Parking Brake | Floor mounted handbrake lever acting on rear axle |
| Enhancements | The system incorporates: Adaptive ESP, ABS, ASR (traction control), BAS (Brake Assist) and EBD (Electronic Brake force Distribution). Electronic Stability Programme is adaptive according to payload. |

FUEL TANK

| | |
|------|---|
| Size | 75 litres; plastic; filler on nearside 'B' pillar (secured behind hinged panel) |
|------|---|

STEERING

Type Rack & pinion; speed sensitive; power assisted

WHEELS & TYRES

Drive Rear wheels
Tyres 235/65R16
Wheels 6.5J x 16
Spare wheel Under rear of vehicle

SUSPENSION

Front MacPherson strut independent with transverse leaf spring
Rear Parabolic leaf springs
Shock absorbers Front and rear
Anti-roll bars Front and rear

CAB

Access to cab: Wide opening driver and passenger doors. Plastic coated entry steps.

Security: Remote central locking, Thatcham Cat 2 engine immobiliser, Attack resistant steering lock, door locks and handles, locking glove box, full height steel bulkhead, interlocked radio CD.

Airbags: Driver's airbag standard with belt tensioner and belt-force limiter. Front passenger airbag, thorax airbags and window bags can also be specified as options.

Seating & Trim 3-way adjustable driver's seat with head restraint; dual passenger seat; three point inertia reel seat belts to all seats. Hard wearing cloth seats; door mounted arm rests; passenger grab handle; moulded ergonomic facia; padded steering wheel with impact resistance centre; cab headlining.

Refinements: Comprehensive insulation from road and engine noise; ashtray; cab interior lighting including map reading light; cigarette lighter; stereo radio/CD with two speakers.

Controls: Hazard warning lights; heater and demister with multiple outlets; horn on steering wheel boss; key start with steering lock and transponder, engine immobiliser; left hand stalk for indicators, lights, main beam, headlamp flasher and parking lights; right hand stalk for two-speed wipers, intermittent wipe and wash/wipe; recirculating air switch and four-speed fan with direction air flow switch.

Instruments: ASSYST - flexible servicing system; coolant temperature gauge; digital clock; digital odometer; fuel gauge; rev counter; speedometer.

CAB (CONT'D)

Warning Lights: ESP/ABS/ASR/EBD warning lights; battery charging indicator; brake pad wear; direction indicators; hazard lights; low brake fluid level; low engine oil; low windscreen washer fluid level; main beam/flasher; parking brake; rear fog lamp.

Visibility: Electrically operated deep opening side windows and fixed quarterlights; laminated windscreen; two large exterior rear view mirrors with separate wide angle lenses; two sunvisors plus shaded windscreen centre.

Stowage: Large pockets in both doors with holders for large bottles; A4 oddments tray on centre of dash; shelves to left and right on instrument panel; 4 cup holders; shelf above windscreen; locking glove compartment; compartment under fold-up passenger seat. Pull-out tray in back of dual passenger seat.

CONSTRUCTION AND FINISH

Construction: All steel integral body/cab.

Body protection: Phosphate treatment, primer and gloss paint finish; floor panels at all joins and contact points on body areas susceptible to corrosion are galvanised; underbody and wheel arches are undersealed with PVC and rust inhibitor.

Service Access: Internally released hinged bonnet for access to - air filter with condition indicator; clutch/brake fluid; engine coolant; engine oil dipstick/filler cap; power steering reservoir; water trap for diesel system; windscreen washer reservoir.

Bumpers: Moulded in damage-resistant, impact-absorbing plastic.

CARGO AREA

Side Access: Nearside lockable sliding side load door with internal access step.

Rear Access: Lockable rear doors with 2 stops. Grab handle on right-hand door pillar. Rear door opening angle of 270°

Interior: Interior load area lighting switched from dashboard or activated by nearside or rear loading doors; wooden floor with bonded resin non-slip finish; flat-topped wheel arches.

Load Restraint: Steel bulkhead; load lashing rings recessed in floor.

Terms and Conditions

Please refer to the latest editions of the Mercedes-Benz Recommended List Price documents for availability and prices of models and optional equipment. The right is reserved to alter specification or equipment without notice. All specifications refer to vehicles sourced in the UK from DaimlerChrysler UK Ltd or their appointed Mercedes-Benz Retail Partners. All weights and dimensions quoted are approximate and subject to normal manufacturing tolerances of +/- 5%.

Sprinter 511 CDI Medium HR Van

| | |
|------------------------------|--|
| ENGINE POWER (hp) | 109 |
| GVW (kg) | 5000 |
| WHEELBASE (mm) | 3665 |
| LOAD SPACE (m ³) | 10.5 |
| LOAD LENGTH (mm) | 3265 |
| WARRANTY (yrs/ mileage) | 3 / unlimited miles |
| CORROSION WARRANTY | 12 years |
| SERVICING | ASSYST - variable 24000-30000 Miles |
| ROADSIDE ASSISTANCE | 3 years |

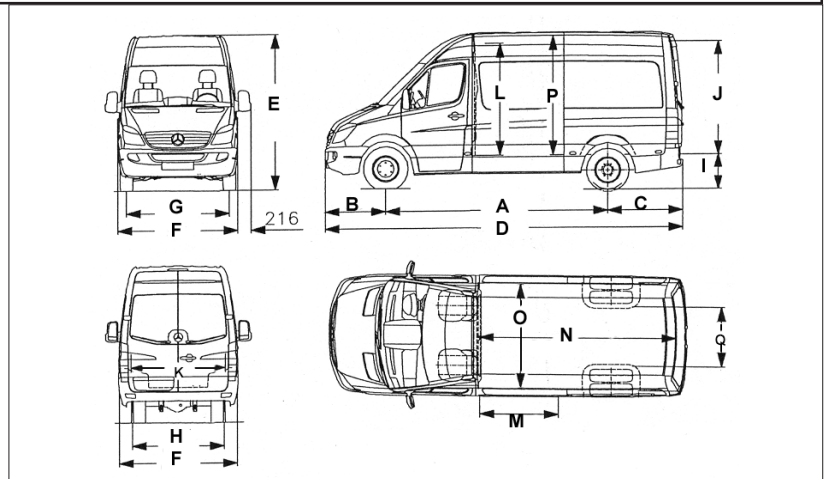

EXTERIOR DIMENSIONS (MM)

| | |
|--------------------------------------|------|
| A Wheelbase | 3665 |
| B Front overhang | 1004 |
| C Rear Overhang | 1240 |
| D Overall Length | 5910 |
| E Overall Height | 2795 |
| F Overall Width | 1993 |
| G Front Track | 1708 |
| H Rear Track | 1521 |
| Turning circle (wall to wall) (m) | 13.6 |

LOAD ACCESS DIMENSIONS (MM)

| | |
|-----------------------|------|
| I Rear Loading Height | 765 |
| J Rear Door Height | 1840 |
| K Rear Door Width | 1562 |
| L Side Door Height | 1816 |
| M Side Door Width | 1300 |

LOAD SPACE DIMENSIONS (MM)

| | |
|-----------------------------|------|
| N Load Length | 3265 |
| O Load Width | 1736 |
| P Interior Height | 1940 |
| Q Width between wheelarches | 978 |
| Load Cube (m ³) | 10.5 |

ENGINE

| | |
|---------------------|---|
| Type | Mercedes-Benz 4 cylinder Diesel Turbocharged & Intercooled with Common Rail direct injection system |
| Capacity | 2.15 litres |
| Maximum power | 109 hp @ 3800 rpm 80kW @ 3800 rpm |
| Maximum Torque | 280 Nm @ 1600-2500 rpm |
| Emission compliance | Euro 4 |

ELECTRICAL

| | |
|---------------------|--|
| Battery | 12 volts, 74 Amp/ hour |
| Standard Alternator | 90 Amp |
| Road Lights | Halogen headlamps with headlamp levelling; indicators; indicator side repeaters in exterior mirrors; tail lights (reverse, fog lights integrated in cluster) |

AXLE RATIOS & VEHICLE PERFORMANCE

| | |
|--------------------------|-------|
| Standard Axle Ratio | 4.727 |
| Geared Speed (mph) | 82 |
| Maximum Gradeability (%) | 40+ |

WEIGHTS (KG)

| | |
|-----------------|------|
| Plated Weights: | |
| Front Axle | 1850 |
| Rear Axle | 3500 |
| GVW | 5000 |
| GTW (braked) | 7000 |
| Kerb Weights: * | |
| Front Axle | 1348 |
| Rear Axle | 1104 |
| Total | 2452 |
| Payload | 2548 |

* According to DIN 70020: incl. driver (65kg), luggage (7kg) and tank 90% full

TRANSMISSION

| | |
|-----------------------|----------------------------------|
| Gearbox | Mercedes-Benz 6 sp. manual |
| Gear Ratios - 1st/Top | 5.453/ 0.777 |
| Gear Lever Position | Dash |
| Clutch | Single dry plate, 240mm diameter |

BRAKE SYSTEM

| | |
|---------------|--|
| Type | Dual circuit hydraulic brake with vacuum servo boost |
| Front/ Rear | Ventilated Disc/ Disc |
| Parking Brake | Floor mounted handbrake lever acting on rear axle |
| Enhancements | The system incorporates: Adaptive ESP, ABS, ASR (traction control), BAS (brake Assist) and EBD (Electronic Brake force Distribuiton) |
| | Electronic Stability Programme is adaptive according to payload. |

FUEL TANK

| | |
|----------|--|
| Standard | 75 litres; plastic; filler on nearside 'B' pillar (secured behind hinged panel) |
|----------|--|

STEERING

Type Rack & pinion; speed sensitive; power assisted

WHEELS & TYRES

Drive Rear wheels
Tyres 205/75R16
Wheels 5.5J x 16 twin rear wheels
Spare wheel Under rear of vehicle

SUSPENSION

Front MacPherson strut independent with transverse leaf spring
Rear Parabolic leaf springs
Shock absorbers Front and rear
Anti-roll bars Front and rear

CAB

Access to cab: Wide opening driver and passenger doors. Plastic coated entry steps.

Security: Remote central locking, Thatcham Cat 2 engine immobiliser, Attack resistant steering lock, door locks and handles, locking glove box, full height steel bulkhead, interlocked radio CD.

Airbags: Driver's airbag standard with belt tensioner and belt-force limiter. Front passenger airbag, thorax airbags and window bags can also be specified as options.

Seating & Trim 3-way adjustable driver's seat with head restraint; dual passenger seat; three point inertia reel seat belts to all seats. Hard wearing cloth seats; door mounted arm rests; passenger grab handle; moulded ergonomic fascia; padded steering wheel with impact resistance centre; cab headlining.

Refinements: Comprehensive insulation from road and engine noise; ashtray; cab interior lighting including map reading light; cigarette lighter; stereo radio/CD with two speakers.

Controls: Hazard warning lights; heater and demister with multiple outlets; horn on steering wheel boss; key start with steering lock and transponder, engine immobiliser; left hand stalk for indicators, lights, main beam, headlamp flasher and parking lights; right hand stalk for two-speed wipers, intermittent wipe and wash/wipe; recirculating air switch and four-speed fan with direction air flow switch.

Instruments: ASSYST - flexible servicing system; coolant temperature gauge; digital clock; digital odometer; fuel gauge; rev counter; speedometer.

CAB (CONT'D)

Warning Lights: ESP/ABS/ASR/EBD warning lights; battery charging indicator; brake pad wear; direction indicators; hazard lights; low brake fluid level; low engine oil; low windscreen washer fluid level; main beam/flasher; parking brake; rear fog lamp.

Visibility: Electrically operated deep opening side windows and fixed quarterlights; laminated windscreen; two large exterior rear view mirrors with separate wide angle lenses; two sunvisors plus shaded windscreen centre.

Stowage: Large pockets in both doors with holders for large bottles; A4 oddments tray on centre of dash; shelves to left and right on instrument panel; 4 cup holders; shelf above windscreen; locking glove compartment; compartment under fold-up passenger seat. Pull-out tray in back of dual passenger seat.

CONSTRUCTION AND FINISH

Construction: All steel integral body/cab

Body protection: Phosphate treatment, primer and gloss paint finish; floor panels at all joins and contact points on body areas susceptible to corrosion are galvanised; underbody and wheel arches are undersealed with PVC and rust inhibitor.

Service Access: Internally released hinged bonnet for access to - air filter with condition indicator; clutch/brake fluid; engine coolant; engine oil dipstick/filler cap; power steering reservoir; water trap for diesel system; windscreen washer reservoir.

Bumpers: Moulded in damage-resistant, impact-absorbing plastic.

CARGO AREA

Side Access: Nearside lockable sliding side load door with internal access step.

Rear Access: Lockable rear doors with 2 stops. Grab handle on right-hand door pillar. Rear door opening angle of 270°

Interior: Interior load area lighting switched from dashboard or activated by nearside or rear loading doors; wooden floor with bonded resin non-slip finish; flat-topped wheel arches.

Load Restraint: Steel bulkhead; load lashing rings recessed in floor.

Terms & Conditions

Please refer to the latest editions of the Mercedes-Benz Recommended List Price documents for availability and prices of models and optional equipment. The right is reserved to alter specification or equipment without notice. All specifications refer to vehicles sourced in the UK from DaimlerChrysler UK Ltd or their appointed Mercedes-Benz Retail Partners. All weights and dimensions quoted are approximate and subject to normal manufacturing tolerances of +/- 5%.

Sprinter 511 CDI Long HR Van

| | |
|------------------------------|--|
| ENGINE POWER (hp) | 109 |
| GVW (kg) | 5000 |
| WHEELBASE (mm) | 4325 |
| LOAD SPACE (m ³) | 14.0 |
| LOAD LENGTH (mm) | 4300 |
| WARRANTY (yrs/mileage) | 3 / unlimited miles |
| CORROSION WARRANTY | 12 years |
| SERVICING | ASSYST - variable 24000-30000 Miles |
| ROADSIDE ASSISTANCE | 3 years |

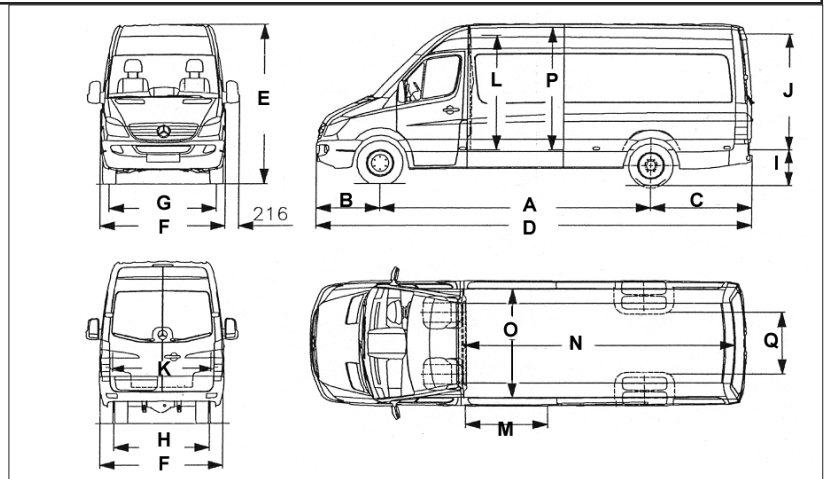

EXTERIOR DIMENSIONS (MM)

| | |
|--------------------------------------|------|
| A Wheelbase | 4325 |
| B Front overhang | 1004 |
| C Rear Overhang | 1615 |
| D Overall Length | 6945 |
| E Overall Height | 2795 |
| F Overall Width | 1993 |
| G Front Track | 1708 |
| H Rear Track | 1521 |
| Turning circle (wall to wall) (m) | 15.6 |

LOAD ACCESS DIMENSIONS (MM)

| | |
|-----------------------|------|
| I Rear Loading Height | 760 |
| J Rear Door Height | 1840 |
| K Rear Door Width | 1565 |
| L Side Door Height | 1816 |
| M Side Door Width | 1300 |

LOAD SPACE DIMENSIONS (MM)

| | |
|-----------------------------|------|
| N Load Length | 4300 |
| O Load Width | 1736 |
| P Interior Height | 1940 |
| Q Width between wheelarches | 978 |
| Load Cube (m ³) | 14.0 |

ENGINE

| | |
|---------------------|---|
| Type | Mercedes-Benz 4 cylinder Diesel Turbocharged & Intercooled with Common Rail direct injection system |
| Capacity | 2.15 litres |
| Maximum power | 109 hp @ 3800 rpm 80kW @ 3800 rpm |
| Maximum Torque | 280 Nm @ 1600-2500 rpm |
| Emission compliance | Euro 4 |

ELECTRICAL

| | |
|---------------------|--|
| Battery | 12 volts, 74 Amp/ hour |
| Standard Alternator | 90 Amp |
| Road Lights | Halogen headlamps with headlamp levelling; indicators; indicator side repeaters in exterior mirrors; tail lights (reverse, fog lights integrated in cluster) |

AXLE RATIOS & VEHICLE PERFORMANCE

| | |
|--------------------------|-------|
| Standard Axle Ratio | 4.727 |
| Geared Speed (mph) | 82 |
| Maximum Gradeability (%) | 40+ |

WEIGHTS (KG)

| | |
|-----------------|------|
| Plated Weights: | |
| Front Axle | 1850 |
| Rear Axle | 3500 |
| GVW | 5000 |
| GTW (braked) | 7000 |
| Kerb Weights: * | |
| Front Axle | 1411 |
| Rear Axle | 1222 |
| Total | 2633 |
| Payload | 2367 |

* According to DIN 70020: incl. driver (65kg), luggage (7kg) and tank 90% full

TRANSMISSION

| | |
|-----------------------|----------------------------------|
| Gearbox | Mercedes-Benz 6 sp. manual |
| Gear Ratios - 1st/Top | 5.453/ 0.777 |
| Gear Lever Position | Dash |
| Clutch | Single dry plate, 240mm diameter |

BRAKE SYSTEM

| | |
|---------------|---|
| Type | Dual circuit hydraulic brake with vacuum servo boost |
| Front/ Rear | Ventilated Disc/ Disc |
| Parking Brake | Floor mounted handbrake lever acting on rear axle |
| Enhancements | The system incorporates: Adaptive ESP, ABS, ASR (traction control), BAS (brake Assist) and EBD (Electronic Brake force Distributon) |
| | Electronic Stability Programme is adaptive according to payload. |

FUEL TANK

| | |
|----------|--|
| Standard | 75 litres; plastic; filler on nearside 'B' pillar (secured behind hinged panel) |
|----------|--|

STEERING

Type Rack & pinion; speed sensitive; power assisted

WHEELS & TYRES

Drive Rear wheels
Tyres 205/75R16
Wheels 5.5J x 16 twin rear wheels
Spare wheel Under rear of vehicle

SUSPENSION

Front MacPherson strut independent with transverse leaf spring
Rear Parabolic leaf springs
Shock absorbers Front and rear
Anti-roll bars Front and rear

CAB

Access to cab: Wide opening driver and passenger doors. Plastic coated entry steps.

Security: Remote central locking, Thatcham Cat 2 engine immobiliser, Attack resistant steering lock, door locks and handles, locking glove box, full height steel bulkhead, interlocked radio CD.

Airbags: Driver's airbag standard with belt tensioner and belt-force limiter. Front passenger airbag, thorax airbags and window bags can also be specified as options.

Seating & Trim 3-way adjustable driver's seat with head restraint; dual passenger seat; three point inertia reel seat belts to all seats. Hard wearing cloth seats; door mounted arm rests; passenger grab handle; moulded ergonomic fascia; padded steering wheel with impact resistance centre; cab headlining.

Refinements: Comprehensive insulation from road and engine noise; ashtray; cab interior lighting including map reading light; cigarette lighter; stereo radio/CD with two speakers.

Controls: Hazard warning lights; heater and demister with multiple outlets; horn on steering wheel boss; key start with steering lock and transponder, engine immobiliser; left hand stalk for indicators, lights, main beam, headlamp flasher and parking lights; right hand stalk for two-speed wipers, intermittent wipe and wash/wipe; recirculating air switch and four-speed fan with direction air flow switch.

Instruments: ASSYST - flexible servicing system; coolant temperature gauge; digital clock; digital odometer; fuel gauge; rev counter; speedometer.

CAB (CONT'D)

Warning Lights: ESP/ABS/ASR/EBD warning lights; battery charging indicator; brake pad wear; direction indicators; hazard lights; low brake fluid level; low engine oil; low windscreen washer fluid level; main beam/flasher; parking brake; rear fog lamp.

Visibility: Electrically operated deep opening side windows and fixed quarterlights; laminated windscreen; two large exterior rear view mirrors with separate wide angle lenses; two sunvisors plus shaded windscreen centre.

Stowage: Large pockets in both doors with holders for large bottles; A4 oddments tray on centre of dash; shelves to left and right on instrument panel; 4 cup holders; shelf above windscreen; locking glove compartment; compartment under fold-up passenger seat. Pull-out tray in back of dual passenger seat.

CONSTRUCTION AND FINISH

Construction: All steel integral body/cab

Body protection: Phosphate treatment, primer and gloss paint finish; floor panels at all joins and contact points on body areas susceptible to corrosion are galvanised; underbody and wheel arches are undersealed with PVC and rust inhibitor.

Service Access: Internally released hinged bonnet for access to - air filter with condition indicator; clutch/brake fluid; engine coolant; engine oil dipstick/filler cap; power steering reservoir; water trap for diesel system; windscreen washer reservoir.

Bumpers: Moulded in damage-resistant, impact-absorbing plastic.

CARGO AREA

Side Access: Nearside lockable sliding side load door with internal access step.

Rear Access: Lockable rear doors with 2 stops. Grab handle on right-hand door pillar. Rear door opening angle of 270°

Interior: Interior load area lighting switched from dashboard or activated by nearside or rear loading doors; wooden floor with bonded resin non-slip finish; flat-topped wheel arches.

Load Restraint: Steel bulkhead; load lashing rings recessed in floor.

Terms & Conditions

Please refer to the latest editions of the Mercedes-Benz Recommended List Price documents for availability and prices of models and optional equipment. The right is reserved to alter specification or equipment without notice. All specifications refer to vehicles sourced in the UK from DaimlerChrysler UK Ltd or their appointed Mercedes-Benz Retail Partners. All weights and dimensions quoted are approximate and subject to normal manufacturing tolerances of +/- 5%.